

## D-DD Type Fender Size Structures

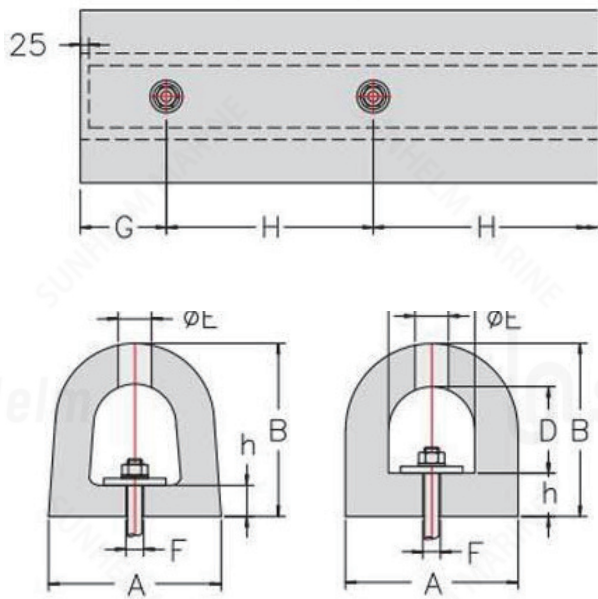

SPEC. (mm)	A	B	C	D	h	$\phi E$	$\phi F$	G	H	FLAT BAR	BOLT SIZE
DD100	100	100	50	50	25	40	20	100-150	200-300	40×8	M16
DD150	150	150	75	75	37.5	50	25	100-150	200-400	60×10	M20
DD200	200	200	100	115*	35*	60	30	100-150	300-500	80×14	M24
DD200	200	200	100	100	50	60	30	100-150	300-500	80×14	M24
DD250	250	250	125	125	62.5	65	33	100-200	300-500	90×14	M27
DD300	300	300	150	185*	40*	65	35	100-200	300-600	110×16	M30
DD300	300	300	150	150	75	65	35	100-200	300-600	110×16	M30
D360	360	360	-	-	40	65	35	100-200	300-600	120×16	M30
DD350	350	350	175	175	87.5	80	38	100-250	300-600	130×16	M33
DD400	400	400	200	245*	55*	80	40	100-250	300-600	135×18	M36
DD400	400	400	200	200	100	80	40	100-250	300-600	150×16	M36
D500	500	500	-	-	90	95	45	100-250	400-600	160×20	M42
DD500	500	500	250	250	250	95	45	100-250	400-600	180×20	M42