

D-DO Type Fender Size Structures

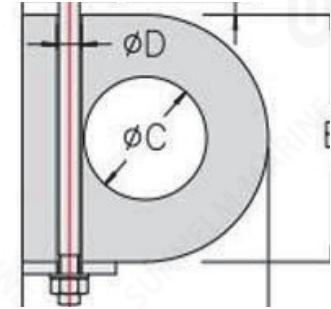
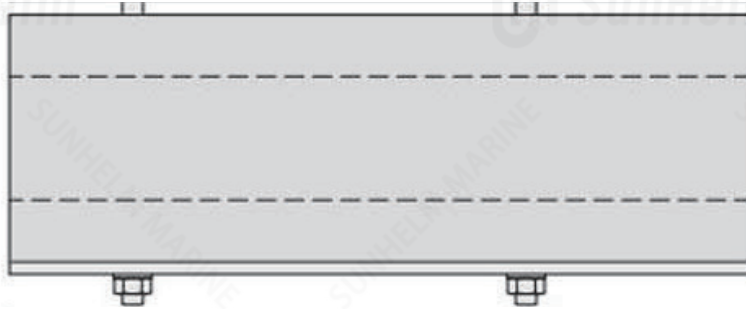
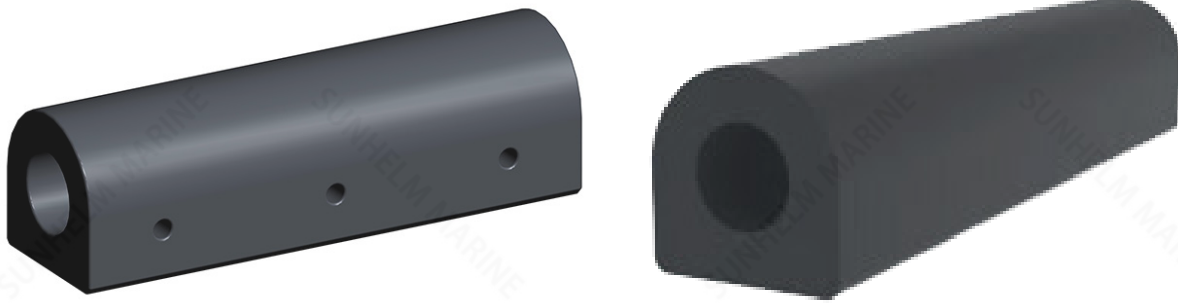

SPEC. (mm)	A	B	ϕC	ϕD	E	F	G	G	FLAT BAR	BOLT SIZE
DC100	100	100	30	20	25	10	100-150	200-300	50X6	M16
DC150	150	150	65	27	30	12	100-150	200-400	60-8	M20
DC200	200	200	75	30	35	15	100-150	300-500	80-10	M24
DC250	250	250	100	33	45	20	100-200	300-500	100-12	M27
DC300	300	300	125	36	55	25	100-200	300-600	110-12	M30
DC350	350	350	150	40	65	25	100-250	300-600	120-12	M30
DC400	400	400	200	45	75	30	100-250	300-600	130-16	M36
DC500	500	500	250	50	95	30	100-250	400-600	130-16	M42

Note:

The value specified in the above table is for reference only. The final drawing is subject to the data provided by the customers